



# PLAZMIR

Plasma Hardening Technology  
for Railway Wheel Flange Life Extension

---

Smarter Wheel Maintenance.  
Longer Wheel Service Life.  
Lower Lifecycle Costs.



**THALAMUS**  
Industrial Technologies





# THE INDUSTRY CHALLENGE

**Railway wheel flange wear** is a major operational problem. Railway wheels operate under severe mechanical stress.

The most vulnerable area is the wheel flange, exposed to intense **lateral wear** caused by:

- curves
- switch crossings
- heavy axle loads
- mountain routes
- braking forces
- dynamic lateral rail contact



Over time, flange wear forces repeated wheel **reprofiling** and **early wheel replacement**.

This creates:



higher maintenance costs



more workshop downtime



increased spare wheel demand



shorter wheel life



operational inefficiency

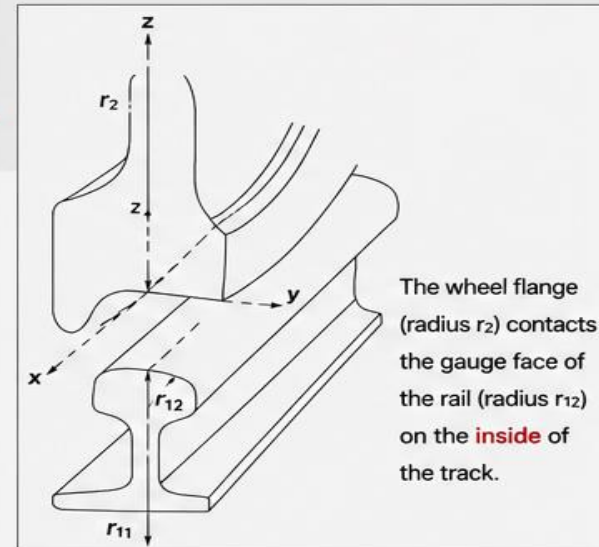



# WHY FLANGE WEAR MATTERS



The flange defines maintenance intervals.



**In standard railway maintenance:**

When flange wear reaches the operational limit, the wheel must be removed for turning (reprofiling).

Each reprofiling operation removes valuable wheel material.



**As this repeats:**

- wheel diameter decreases
- wheel structural reserve shrinks
- useful service life shortens
- replacement arrives much earlier

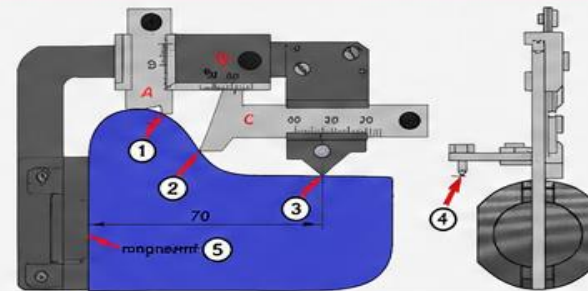
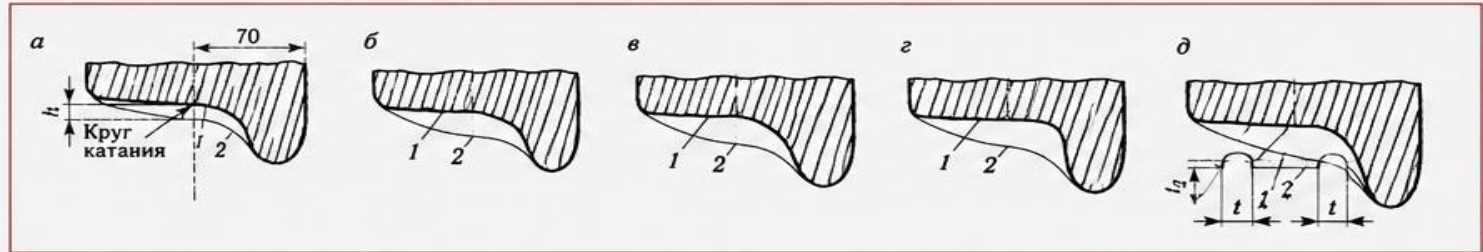
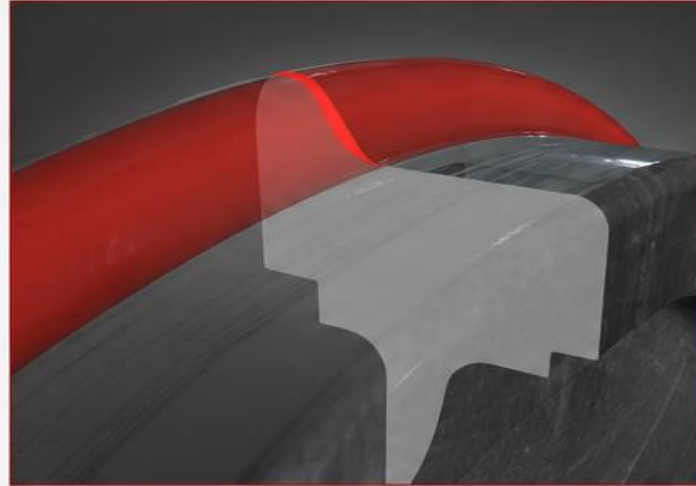

**Without intervention,  
the wheel becomes a recurring maintenance expense.**



# STANDARD MAINTENANCE MODEL

Conventional wheel lifecycle

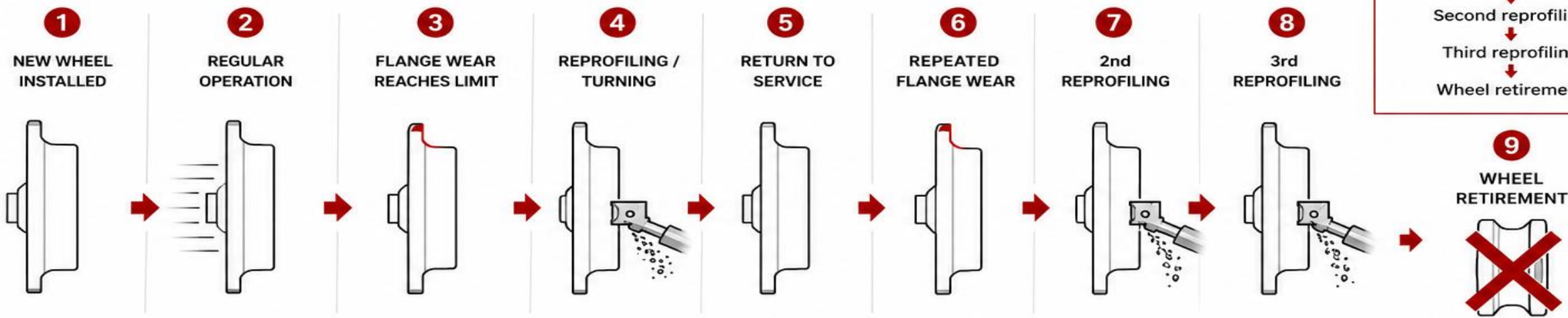

THIS TRADITIONAL CYCLE CONSUMES:



LABOR



MACHINE TIME



SPARE INVENTORY



OPERATIONAL AVAILABILITY



CAPITAL BUDGET



Each maintenance cycle **removes wheel material** — reducing total asset life.



# PLAZMIR SOLUTION

Controlled plasma hardening of the wheel flange

PLAZMIR introduces a targeted plasma hardening process applied directly to the wheel flange wear zone.



### IMPORTANT CLARIFICATION:

PLAZMIR does NOT treat the wheel tread or rail contact surface.

The treatment is focused exclusively on the flange area exposed to lateral wear.



### APPLICATION OCCURS:

after wheel reprofiling / turning



This creates a **hardened wear-resistant surface** while preserving wheel functionality.

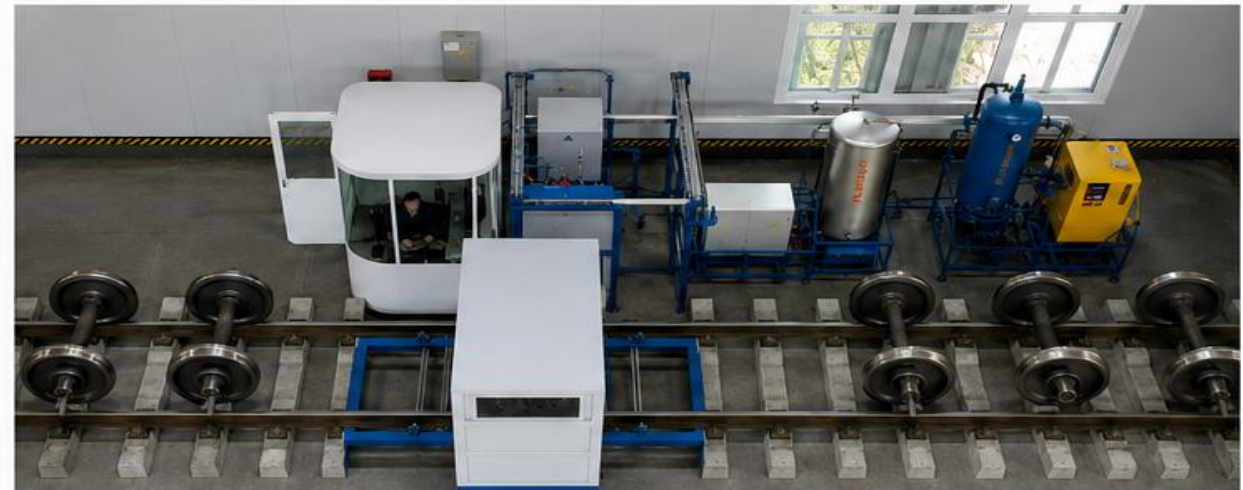
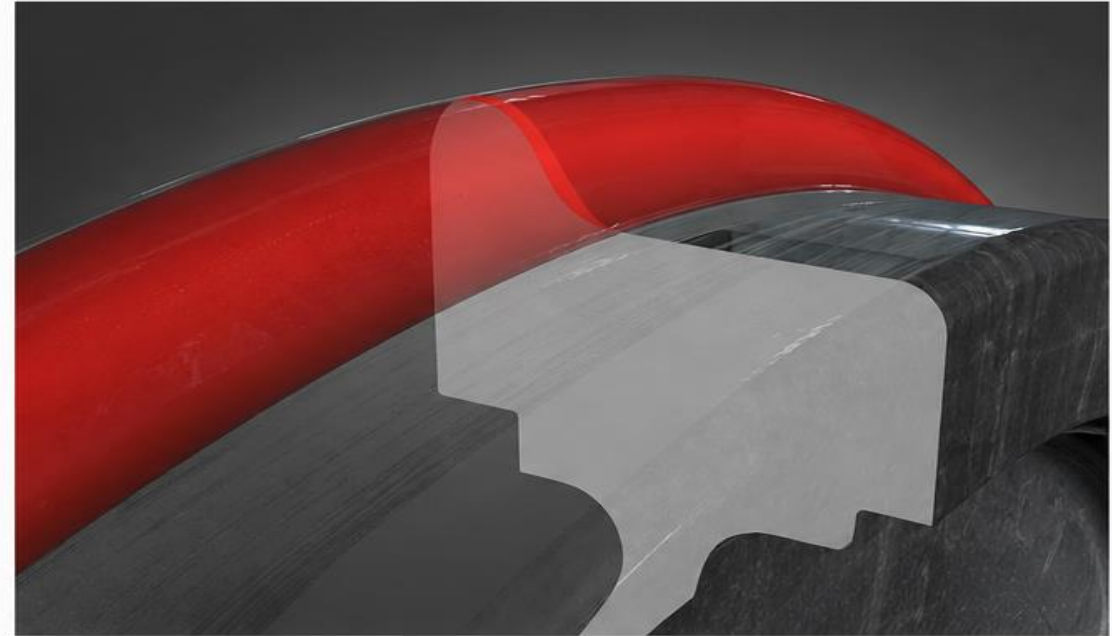

# HOW PLAZMIR WORKS

Targeted plasma hardening where wear actually occurs

PLAZMIR uses a controlled plasma process to strengthen the wheel flange surface after maintenance reprofiling.

## THE PROCESS CREATES:

- ✓ Increased surface hardness
- ✓ Improved wear resistance
- ✓ Stable metallurgical structure
- ✓ Preserved mechanical integrity
- ✓ Resistance to repeated lateral stress



## RESULT:

The flange wears significantly slower under real railway operating conditions.

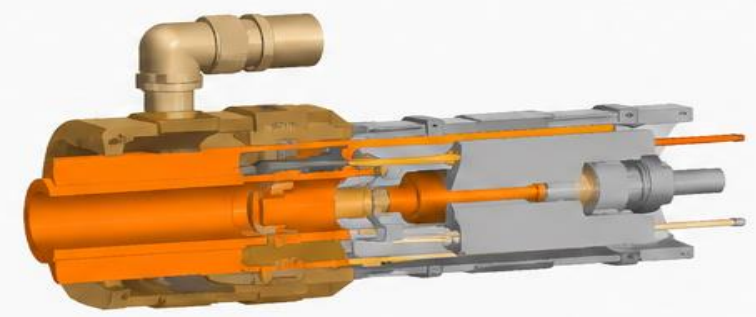
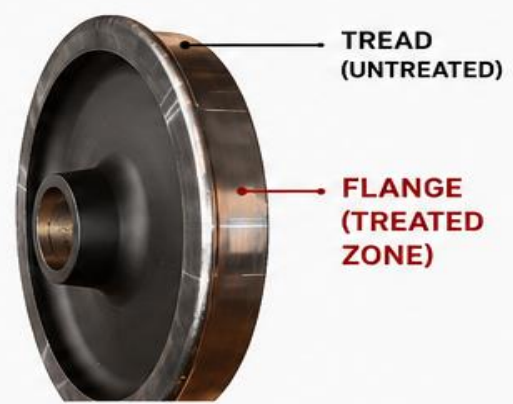

PLAZMIR PLASMA UNIT (CUTAWAY)

## MICROSTRUCTURE BENEFIT:



Untreated surface



PLAZMIR hardened surface



Hardened, wear-resistant surface built for real railway conditions



## BEFORE PLAZMIR vs. WITH PLAZMIR

### WITHOUT PLAZMIR

Conventional maintenance cycle

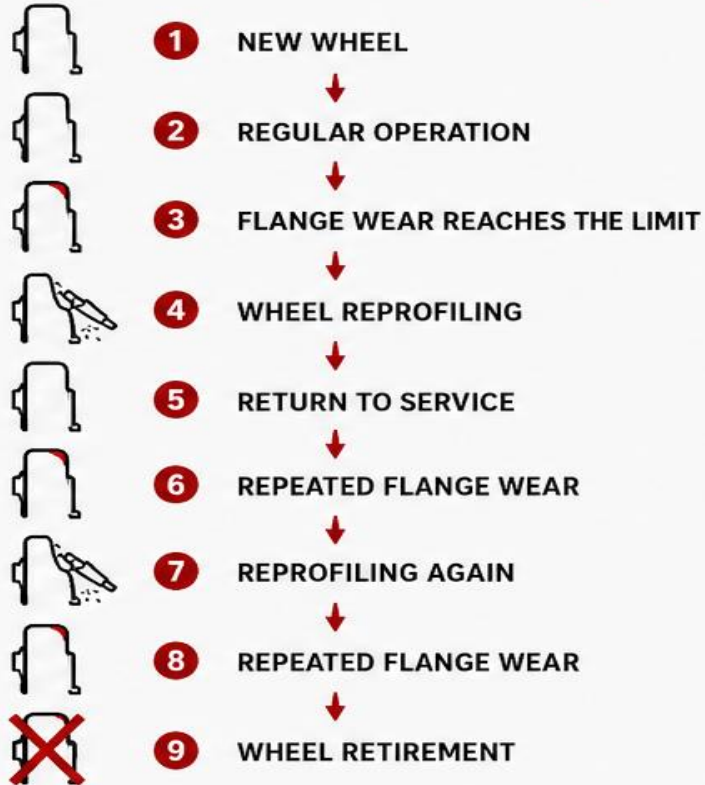

Repeated material loss • Frequent workshop interventions • Shorter asset life



### WITH PLAZMIR

PLAZMIR-optimized maintenance cycle

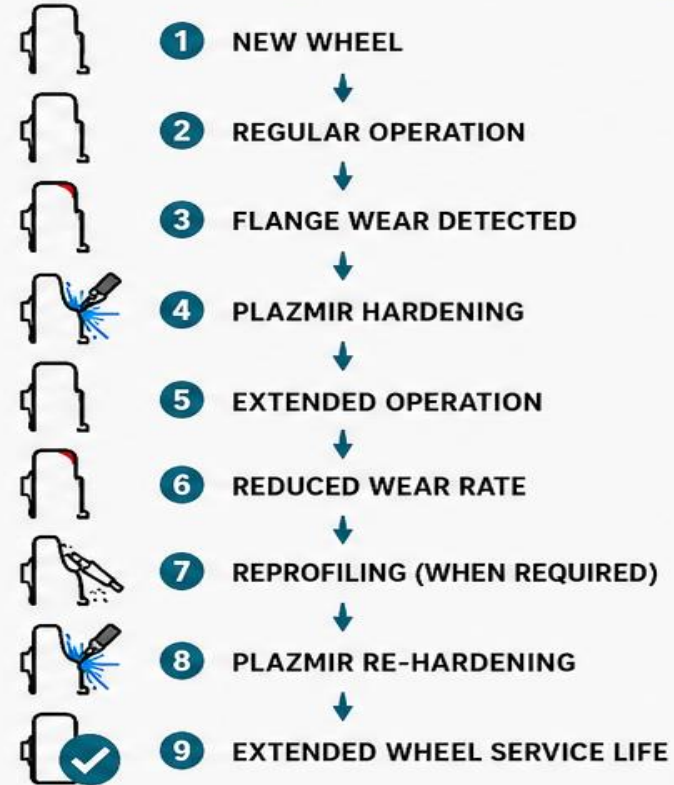

Longer service intervals • Fewer interventions  
Optimized lifecycle



## OPERATIONAL DIFFERENCE

Why the maintenance model changes



### IN THE TRADITIONAL CYCLE:

Flange wear directly leads to frequent reprofiling.

This means:

- ✗ Faster material loss
- ✗ Shorter wheel life
- ✗ Repeated workshop interventions
- ✗ More downtime



### WITH PLAZMIR:

Flange wear progression slows significantly.

This allows:

- ✓ Longer intervals between interventions
- ✓ Fewer reprofiling operations
- ✓ Reduced material loss
- ✓ Improved asset utilization



### TRADITIONAL CYCLE



### WITH PLAZMIR



CORE OPERATIONAL RESULT:

**2-3x INCREASE IN FLANGE SERVICE INTERVAL**



## TECHNICAL ADVANTAGES

Built for industrial railway maintenance environments

### PLAZMIR PROVIDES:



#### TARGETED TREATMENT

Only the critical flange wear zone is processed.



#### CONTROLLED THERMAL IMPACT

Localized plasma application minimizes unnecessary thermal exposure.



#### REPEATABLE INDUSTRIAL PROCESS

Designed for standardized railway maintenance workflows.



#### COMPATIBILITY WITH MAINTENANCE CYCLES

Integrates naturally into existing reprofiling procedures.



#### FLEXIBLE DEPLOYMENT

Can be implemented in different maintenance configurations.



#### SCALABLE ARCHITECTURE

Suitable for depot, industrial, and large railway fleet operations.

### FLEXIBLE PLAZMIR PORTAL CONFIGURATIONS



**BASIC PORTAL**

PLASMA HARDENING ONLY



**ADVANCED PORTAL**

+ WHEELSET GEOMETRY CONTROL



**PREMIUM PORTAL**

+ GEOMETRY CONTROL  
+ CONTACT ZONE NDT

#### ADDITIONAL MODULES

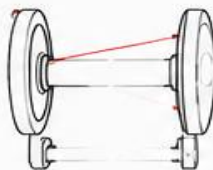

#### WHEELSET GEOMETRY CONTROL

High-precision measurement of wheel diameter, profile, flange height, back-to-back distance and other critical parameters.

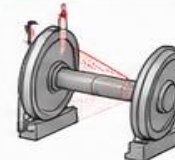

#### CONTACT ZONE NDT

Non-destructive testing of the wheel tread (contact surface) to detect internal and surface defects.



### CERTIFIED WHEELSET PASSPORT – COMPLETE TRACEABILITY

Each wheelset processed with PLAZMIR can be issued a digital passport including:

- ✔ Geometry data
- ✔ NDT inspection results
- ✔ Processing parameters
- ✔ Maintenance history
- ✔ Recommendations



**THIS MAKES THE PLAZMIR COMPLEX INDISPENSABLE FOR PREDICTING DEFECTS, ELIMINATING RISKS AND PREVENTING FAILURES ON RAILWAYS WORLDWIDE.**



IMPROVED SAFETY



REDUCED DOWNTIME



OPTIMIZED COSTS



SUSTAINABLE RELIABILITY

# DEPLOYMENT FLEXIBILITY

Built for real railway operations

PLAZMIR is designed for practical industrial deployment across different maintenance environments.

## POSSIBLE IMPLEMENTATION MODELS INCLUDE:



### DEPOT-BASED INSTALLATION

Permanent integration into railway maintenance workshops.

#### IDEAL FOR:

- ✓ Centralized maintenance depots
- ✓ National railway fleets
- ✓ Large repair centers
- ✓ Scheduled maintenance operations



### MOBILE FIELD DEPLOYMENT

Flexible treatment capability closer to operational infrastructure.

#### IDEAL FOR:

- ✓ Distributed railway networks
- ✓ Regional maintenance support
- ✓ Rapid intervention scenarios
- ✓ Remote operational environments



**RESULT:**

**TECHNOLOGY ADAPTS TO RAILWAY OPERATIONS — NOT THE OPPOSITE.**

# PARTNERSHIP & COOPERATION

Open for industrial collaboration

THALAMUS welcomes cooperation with:

- railway operators
- industrial engineering groups
- manufacturing partners
- maintenance organizations
- infrastructure modernization programs
- strategic investors
- industrial technology partners

Collaboration models may include:

- deployment partnerships
- localized manufacturing
- technical cooperation
- industrial integration
- commercialization partnerships





# PLAZMIR

Smart Plasma Technology for  
Railway Wheel Life Extension



Longer service intervals.



Lower lifecycle costs.



Smarter railway maintenance.



**THALAMUS**  
Industrial Technologies

**Contact:**

✉ [thalamusgroup.kostiantyn@gmail.com](mailto:thalamusgroup.kostiantyn@gmail.com)

☎ +421 903 848 248



**THALAMUS**



**GNARUS**